

V5 | SEPTEMBER | 2024

OVER 130 YEARS
OF INNOVATION

PRICE LIST

2024



REZNOR®

REZNOR®

1

OPTION 1 SALES

reznorquotes@nortek.com | reznorsales@nortek.com

- Pricing, Orders and Quotes • Technical Designs & Support (pre-sales)
- Spares • Invoice Queries

2

OPTION 2 POST SALES TECHNICAL SUPPORT

technicalsupport.hvac@nortek.com

- Installation Support • Wiring Advice • Trouble Shooting

3

OPTION 3 SERVICE

serviceuk.hvac@nortek.com

- Report a Fault • Warranty Call Outs
- Arrange Commissioning

4

OPTION 4 ACCOUNTS & SUPPLY CHAIN

hvacuk.creditcontrol@nortek.com

- Credit Limit Advice • Opening a New Account

01384 489 700

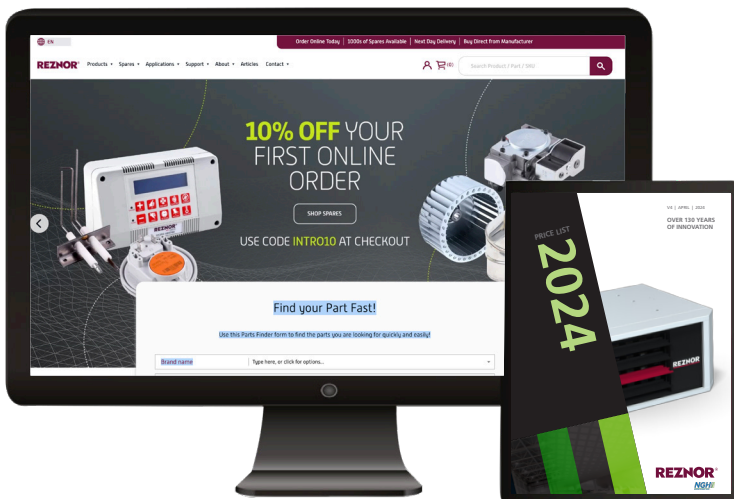

REZNOR®

SPARES - VIEW AND ORDER ONLINE

We have an easy to use online spares platform called REZNOR.

This contains spare parts for all Nortek branded products, past and present, including Reznor, AmbiRad, NordairNiche, Benson and AirBloc . Visit www.reznor.co.uk to order now.

WEBSITE & LIBRARY

Did you know Reznor has extensive online resources available for you? Find the latest updates and product news on www.reznor.co.uk

You can now access technical literature and information on spare parts for Reznor, AmbiRad, NordairNiche, Benson and AirBloc units at literature.reznor.eu

Request a design for a new project and order your heaters and quotes online.

 facebook.com/ReznorHVAC

 @ReznorUK

 linkedin.com/company/reznor-uk-ltd

Radiant Tube

	Page
VSUTE - U Tube Models	05
VSLIE - Linear Models	06
VSDLE - Double Linear Models	07
Accessories - Vision models	08
Accessories - Vision models	09/10
Accessories - Vision models	11
SCR-ECO - Gas Fired Radiant Plaque	12
Titan - Electric Radiant Heaters	13
Sorrento - Electric Radiant Heaters	13
Quartzglow - Electric Radiant Heaters	14
Sonning ² OHA - Single Burner Continuous Radiant Tube System	15
Nor-Ray-Vac - Gas Fired Continuous Radiant Tube System	16

Warm Air Heaters

RHeco - Gas Fired Condensing Suspended Unit Heaters	17
Photon - Gas Fired Unit Heater	18
Sealed Stainless Steel Flue - for Gas Fired Unit Heaters	19
e ⁺ Electric Warm Air Heater	20
DS - Destratification Fans	21
BIG ASS FANS - Destratification Fans	22
BIG ASS FANS - Destratification Fans	23
Comet+ - Cabinet Heaters	24
Comet+ - Flue	25/26
NOVAEMS - Energy Management System	27/28
Sonniger - Heater Condens	29
Echo - Air Rotation Units	30
Genco - Modular Air Handling System	31
AirMix - High Induction Duct Distribution System	32
Smitsair - High Induction Nozzles	33

Air Curtains

Guardian GS - Surface Mounted Series	34
Guardian GR - Recessed Mounted Series	35
Accessories - for Guardian Series	36
AC Mini Series - Mini Surface Mounted & Recessed Series	37
ACT - Electric Ceiling Tile Heaters	38
AB - Industrial Series	39/40
Accessories - for AB Industrial Series	41

Miscellaneous

Carriage charges	42/43
Terms & Conditions	44
Warranty	45

Our history...

For over 130 years, Reznor has gone from strength to strength, consistently evolving to better serve its customers and maintain its position as a leading provider of heating, cooling and ventilation solutions.

Since the early days as the favoured producer of gas fired stoves for heating residential homes, Reznor has evolved to be the preferred name in industrial and commercial HVAC solutions.

NORTEK BRAND LEGACY

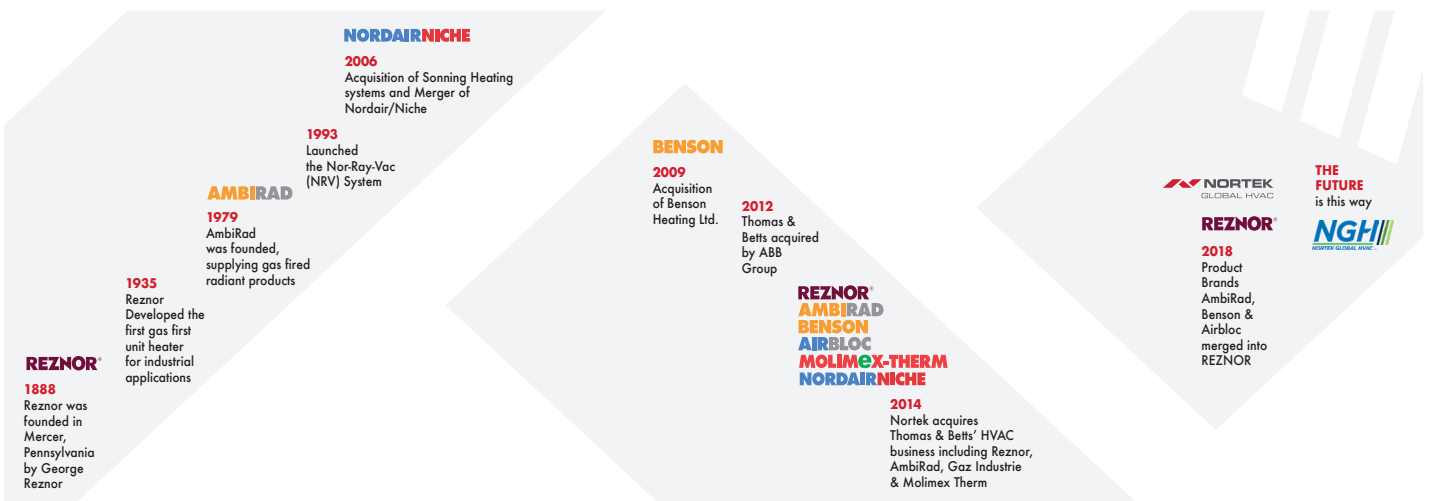



VSUTE

VS models are supplied complete with turbulators, aluminised steel reflector and endcaps.

VISION VSUTE U-TUBE MODELS (INDUCED BURNER) | PROPANE MODELS AVAILABLE

MODEL	DESCRIPTION	HEAT INPUT kW	GAS RATE (m3/h)	NAT GAS	LPG	LENGTH (m)	LIST PRICE
VS15UTEN	U-TUBE	15.0	1.4	1	1	4.5	1723.28
VS25UTEN	U-TUBE	23.5	2.3	1	1	5.1	1973.75
VS35UTEN	U-TUBE	36.0	3.4	1	4	7.6	2388.78
VS40UTEN	U-TUBE	40.0	3.8	4	4	8.5	2512.98
VS45UTEN	U-TUBE	44.0	4.2	4	5	9.3	2636.15
VS50UTEN	U-TUBE	48.0	4.6	4	5	9.3	2764.49

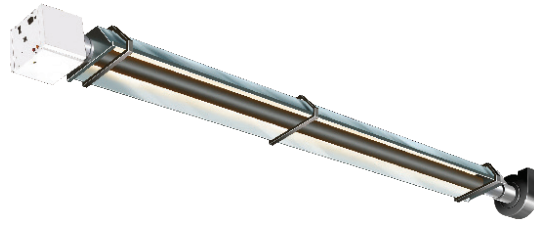

VSLIE STANDARD

VSLIE models are supplied complete with turbulators, aluminised reflector and end caps.

VISION VSLIE LINEAR MODELS (INDUCED BURNER) - STANDARD LENGTH MODELS - PROPANE MODELS AVAILABLE

MODEL	DESCRIPTION	HEAT INPUT kW	GAS RATE (m3/h)	FLUE ADAPTER REFERENCE		LENGTH (m)	LIST PRICE
				NAT GAS	LPG		
VS15LIEN8	STANDARD 'SL' TUBE	15.0	1.4	1	1	8.0	1707.75
VS25LIEN8	STANDARD 'SL' TUBE	23.5	2.3	1	1	8.0	1893.02
VS35LIEN10-5	STANDARD 'SL' TUBE	36.0	3.4	1	4	10.5	2260.44
VS40LIEN13-5	STANDARD 'SL' TUBE	40.0	3.8	1	4	13.5	2455.02
VS45LIEN13-5	STANDARD 'SL' TUBE	44.0	4.2	1	4	13.5	2485.04
VS50LIEN13-5	STANDARD 'SL' TUBE	48.0	4.6	4	4	13.5	2569.91

VSLIE EXTENDED

VSLIE models are supplied complete with turbulators, aluminised reflector and end caps.

VISION VSLIE LINEAR MODELS (INDUCED BURNER) - EXTENDED LENGTH MODELS - PROPANE MODELS AVAILABLE

MODEL	DESCRIPTION	HEAT INPUT kW	GAS RATE (m3/h)	FLUE ADAPTER REFERENCE		LENGTH (m)	LIST PRICE
				NAT GAS	LPG		
VS25LIEN10-5	EXTENDED 'SL' TUBE	23.5	2.3	1	1	10.5	2117.61
VS35LIEN13-5	EXTENDED 'SL' TUBE	36.0	3.4	1	4	13.5	2403.27
VS40LIEN16	EXTENDED 'SL' TUBE	40.0	3.8	4	4	16	2640.29
VS45LIEN16	EXTENDED 'SL' TUBE	44.0	4.2	4	4	16	2673.41
VS50LIEN16	EXTENDED 'SL' TUBE	48.0	4.8	4	4	16	2828.66

VSLIE MODELS CAN BE USED IN A HERRINGBONE SYSTEM INCORPORATING UP TO 10 HEATERS
PLEASE CALL 01384 489700 FOR DETAILS

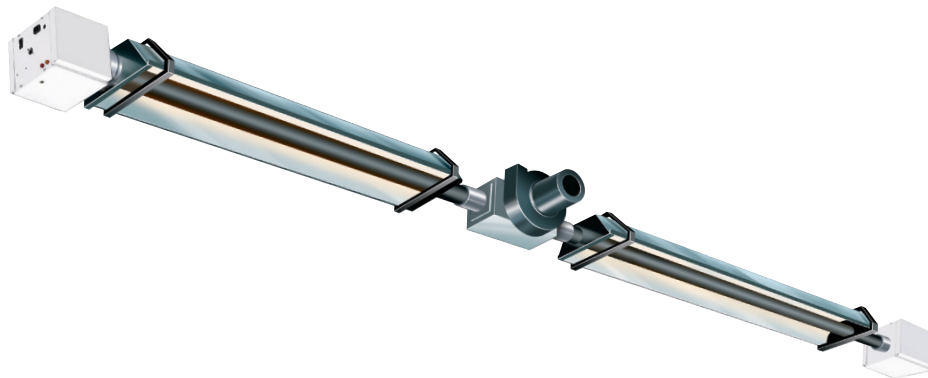

VSDLE
STANDARD

VS models are supplied complete with turbulators, aluminised steel reflector and endcaps.

Vision VSDLE double linear models (induced burner) - Standard length models | PROPANE MODELS

MODEL	DESCRIPTION	HEAT INPUT KW	GAS RATE (m3/h)	FLUE ADAPTER REFERENCE		LENGTH (m)	LIST PRICE
				NAT GAS	LPG		
VS15DLEN16	Standard 'DL' Tube	30.0	2.8	4	4	16.0	3573.86
VS25DLEN16	Standard 'DL' Tube	47.0	4.6	4	4	16.0	3976.47
VS35DLEN21	Standard 'DL' Tube	72.0	6.8	4	4	21.0	4747.55
VS40DLEN27	Standard 'DL' Tube	80.0	7.6	4	4	27.0	5101.52
VS45DLEN27	Standard 'DL' Tube	88.0	8.4	5	5	27.0	5199.84
VS50DLEN27	Standard 'DL' Tube	96	9.2	5	5	27.0	5393.39

VSDLE
EXTENDED

VS models are supplied complete with turbulators, aluminised steel reflector and endcaps.

Vision VSLIE double linear models (induced burner) - Extended length models | PROPANE MODELS

MODEL	DESCRIPTION	HEAT INPUT KW	GAS RATE (m3/h)	FLUE ADAPTER REFERENCE		LENGTH (m)	LIST PRICE
				NAT GAS	LPG		
VS25DLEN21	Extended 'DL' Tube	47.0	4.6	4	4	21.0	4335.62
VS35DLEN27	Extended 'DL' Tube	72.0	6.8	4	4	27.0	4918.32
VS40DLEN32	Extended 'DL' Tube	80.0	7.6	4	4	32.0	5385.11
VS45DLEN32	Extended 'DL' Tube	88	8.4	5	5	32.0	5585.90
VS50DLEN32	Extended 'DL' Tube	96	9.2	5	5	32.0	5903.64

PART NUMBER	DESCRIPTION	LIST PRICE
6506	1/2" Gas Valve	21.32
6500	1/2" Flexible gas connection (600mm long) Plastic coated stainless steel with union to BS6501 part1. 1991 Class "C" construction	57.75
6500-2	1/2" Flexible gas connection (1.0m long for use with VS40LIE and above) Plastic coated stainless steel with union to BS6501 part1. 1991 Class "C" construction	65.21
6515	Suspension chain (galvanised, 10m length)	38.54
6516	Suspension chain (galvanised, 90m length)	323.09
6524-SUB	Speedlinks x 8	22.26
6518	D Shackle (galvanised) each	5.15
C766300-SUB	Tumbuckle assembly	13.46
V-LO	Vision Lockout Conversion Kit	190.84
6124	Run on timer (0 to 2hrs)	225.07
1350-3	Undershield deflector 2438mm long c/w 2 x 3" munson rings. For models VS15 to 25	117.12
1350-4	Undershield deflector 2438mm long c/w 2 x 4" munson rings. For models VS35 to 50	149.76

Protective Wire Guard

PART NUMBER	DESCRIPTION	MODEL/DESCRIPTION	LIST PRICE
BG15UTE	U-TUBE	VS15UTEN	316.79
BG20-25UTE	U-TUBE	VS25UTEN	475.76
BG30-35UTE	U-TUBE	VS35UTEN	547.79
BG40UTE	U-TUBE	VS40UTEN	547.79
BG45-50UTE	U-TUBE	VS45UTEN & 50UTEN	681.77
BG3LE8	LINEAR	VS15LEN 8m	264.08
BG3LE10-5	LINEAR	VS25LEN 10.5m	334.74
BG4LE10-5	LINEAR	VS35LEN 10.5m	606.69
BG4LE13-5	LINEAR	VS35LEN, 40LEN, 45LEN & 50LEN 13.5m	746.13
BG4LE16	LINEAR	VS40LEN, 45LEN & 50LEN 16m	920.43
6569		Black bulb sensor guard	49.04

Wall Mounting Brackets

PART NUMBER	DESCRIPTION	BRACKETS REQUIRED PER HEATER	LIST PRICE
1001836	VS35 & 40 U-TUBES	4	64.04
1001836	VS45 & 50 U-TUBES	5	64.04
1001836	VS15 & 25 8m Linear	4	64.04
1001836	VS25 & 35 10.5m Linear	5	64.04
1001836	VS35, 40, 45 & 50 13.5m Linear	6	64.04
1001836	VS40, 45 & 50 16m Linear	7	64.04

Fresh Air Intake Kit & Adaptors (100mm diameter, single skin aluminium)

PART NUMBER	DESCRIPTION	LIST PRICE
VSI-DA	VS & VSLI Ducted Air Adaptor	177.80
FAFK-4	Fresh air intake kit (3m x 100mm ID aluminium lengths of pipe (7070-SUB), 1 x rubberised flashing plate & fixing kit (33-51-022) & 1 x 100mm dia terminal (L101590-SUB))	189.00

Flue Connectors

PART NUMBER	DESCRIPTION	ADAPTER REF	LIST PRICE
7177-SUB	125mm (5") Fan/flue connector	1	49.46
7176-SUB	125mm (5") Fan/flue connector	4	51.98
202365	125mm (5") Fan/flue connector	5	52.08

Twin Wall Flue Components (125mm diameter, 140mm outside diameter)

PART NUMBER	DESCRIPTION	LIST PRICE
7156-FLUE33	914mm Length of pipe	129.99
7157-FLUE32	1524mm Length of pipe	200.66
7158-FLUE31	450mm Adjustable length of pipe	361.31
33-51-222	Rubberised roof plate with fixing kit	96.81
7162-FLUE34	Gas vent Terminal/cowl	104.58
7166-FLUE30	Adjustable elbow 0 to 90°	101.85

Twin Wall Flue Kits

PART NUMBER	DESCRIPTION	LIST PRICE
TWFK-5A-1	Kit 'A' 1 x 1524mm length tube (7157-FLUE32), 1 x 914mm length tube (7156-FLUE33), 1 x 450mm adjustable length flue (7158-FLUE31), rubberised roof plate and fixing kit (33-51-222) and terminal (7162-FLUE34)"	664.02
TWFK-5B-1	Kit 'B' as Kit 'A' plus 2 adjustable elbows (7166-FLUE30)	821.00

SmartCom controls

PART NUMBER	MODEL	LIST PRICE
B-SC3ML-SZR	SmartCom single zone controller Std functions include (but not limited to):- single stage heating, self-adapting optimised start, volt free BMS over-ride, timeclock with overtime facility, fan only operation, frost protection, night set- back, burner lockout indication with reset, internal thermostat	343.56
B-SC3ML-MZR	SmartCom multi zone controller As single zone model, but with the following additional functions: two stage heating & cooling, modulating burner control, networking function	483.11
29-01-222	SmartCom black bulb sensor	75.92



V5 | SEPTEMBER | 2024

SCR-ECO

SCR-ECO units are for use with natural gas as standard and are fitted with a fully automatic burner ignition system requiring a 240v single phase electrical supply. Each unit is supplied with wall mounting brackets and a loose LPG jet.

MODEL	DESCRIPTION	HEAT INPUT KW	LIST PRICE
SCR-ECO-7/4	7.5kW gas fired plaque heater	7.5	1078.47
SCR-ECO-18/10	17.5kW gas fired plaque heater	17.5	1298.93
SCR-ECO-29/16	27.0kW gas fired plaque heater	27	1519.79
SCR-ECO-44/12+12	41.8kW gas fired plaque heater	41	2121.75

Sundries

PART NUMBER	DESCRIPTION	LIST PRICE
6506	½" BSP Gas tap	21.32
6500	½" BSP Flexible connector 600mm long	57.75



Titan Electric Radiant Heater

MODEL	DESCRIPTION	HEAT INPUT KW	DIMENSIONS (mm)	MOUNTING HEIGHT (mm)	LIST PRICE
TI-STAT	Static heater	3.0	669 x 430 x 509	2.0	815.58



Sorrento

The Sorrento range is a robust weatherproof heater available in three configurations. All models are supplied with a wall mounting bracket & for use with single phase electrical supply.

SORRENTO ELECTRIC HEATER | BRACKETS INCLUDED STOCKED IN BLACK, SILVER & WHITE. SUBJECT TO AVAILABILITY

MODEL	DESCRIPTION	HEAT INPUT KW	DIMENSIONS (mm)	MOUNTING HEIGHT (mm)	LIST PRICE
SOR15-BLACK	Single linear tube	1.5	402 x 227 x 112	2.0	449.19
SOR15-SILVER	Single linear tube	1.5	402 x 227 x 112	2.0	449.19
SORDL30-BLACK	Double linear tube	3.0	790 x 227 x 112	2.5 to 4.0	763.83
SORDL30-WHITE	Double linear tube	3.0	790 x 227 x 112	2.5 to 4.0	763.83
SORDL30-SILVER	Double linear tube	3.0	790 x 227 x 112	2.5 to 4.0	763.83
SORTL45-BLACK	Double linear tube	4.5	1178 x 227 x 112	2.5 to 4.0	1098.14
SORTL45-WHITE	Double linear tube	4.5	1178 x 227 x 112	2.5 to 4.0	1098.14



Quartz glow

The Apollo range of indoor heaters, manufactured from extruded aluminium, offers a choice of power options 1.5kW - 9kW to suit all situations and requirements. They are adjustable both vertically and horizontally for accurate heat placement. Safety guards are available where required.

APOLLO ELECTRIC HEATER | BRACKETS INCLUDED AVAILABLE IN BLACK, SILVER & WHITE. SUBJECT TO AVAILABILITY

MODEL	DESCRIPTION	HEAT INPUT KW	DIMENSIONS (mm)	MOUNTING HEIGHT (mm)	LIST PRICE
QH 15-1	Single tube	1.5	422 x 255 x 110	2.0 to 4.0	482.31
QH 30-1	Double tube	3.0	422 x 390 x 110	3.0 to 4.5	783.50
QH 45-1	Triple tube	4.5	422 x 525 x 110	3.5 to 5.5	1010.16
QH 45-3	Triple tube - 3ph	4.5	422 x 525 x 110	3.5 to 5.5	1081.58
QHL 30-1	Double linear tube	3.0	857 x 255 x 110	3.0 to 4.5	826.97
QHL 45-1	Triple linear tube	4.5	1282 x 255 x 110	3.5 to 5.5	1142.39
QHL 45-3	Triple linear tube	4.5	1282 x 255 x 110	3.5 to 5.5	1192.26
QHL 90-3	Triple double linear tube - 3ph	9.0	857 x 630 x 110	5.0 to 7.0	1997.55

Sonning² OHA is a continuous gas fired radiant tube heating system fitted with either a single internal or external burner, which employs 80% flue gas re-circulation and is designed specially for the building it is required to heat.

The inclusion of modulating burner on the OHA RHE ranges enables thermal efficiencies of up to 96% to be achieved.

The OHA system is designed to provide uniform heat coverage over the entire floor area. The system can also cater for distinct zones providing a varied degree of comfort level within the overall layout of the building.

Nortek strives to become part of the 'design team', working closely with engineers or end users to determine the specific design parameters for the OHA scheme layout. This contact between the company's engineers and the system designer or client will give the most effective OHA system.

Model Range

The OHA Series radiant tube heating system includes nine natural gas or propane burner models from 50 to 400kW, radiant tube lengths from 25 to 400 metres. Maximum tube temperatures range from 200°C to 350°C.

The OHA RHE Modulating Series radiant tube heating system includes 6 natural gas or propane burner models from 100 to 370kW, radiant tube lengths from 35 to 250 metres. Maximum tube temperatures range from 120°C to 290°C.

The heaters will operate equally as effective on a wide variety of fuels; natural gas, LPG and oil (OHA only)

Sonning² OHA

SONNING²

Please contact sales on 01384 489700 for more information on Sonning² continuous radiant tube system

£POA

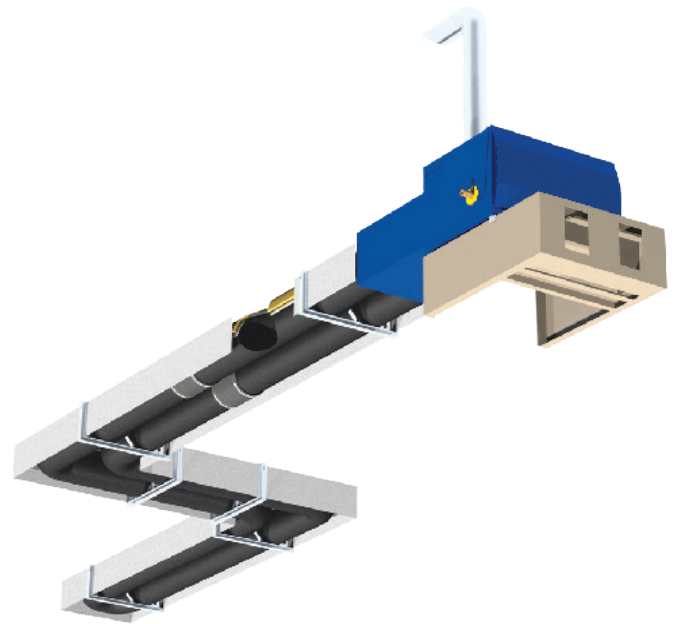

Introducing the revitalized Nor-Ray-Vac, your trusted radiant system, back by popular demand with cutting edge technology and market leading excellence poised to meet the evolving needs of our customers.

The Nor-Ray-Vac is a gas fired continuous radiant tube heating system, uniquely designed and specified for the building it is required to heat. The following criteria form the basis of each particular system design:

- Heat loss of the building for the required thermal environment
- Local climate conditions
- Type of activity in the building
- Specific architectural features relating to the structure

The Nor-Ray-Vac is a conventional radiant heating system, that operates with on/off control and continuous modulation. This is achieved by adjusting the vacuum as the building temperature varies. The optimum air/ gas ratio is maintained giving maximum comfort & efficiency whilst minimising fuel consumption.

Features include:

- Reduces overall costs, with savings of up to 60% being achieved over conventional heating systems
- Stoichiometric or 'perfect' combustion
- Can be designed to a 92% combustion efficiency & >92% thermal efficiency
- Good aesthetic integration with building

Model Range

The Nor-Ray-Vac Series continuous radiant tube heating system is available in natural gas or propane versions. There are four models in the range - 24kW, 32kW, 38kW and 46kW output - with maximum radiant tube lengths from 9.4 to 27 meters.

Modulating burners are provided on all models allowing them to modulate from 50% to 100% duty (24/12kW, 32/16kW, 38/19kW and 46/23kW). Maximum tube temperatures range from 450°C to 480°C.

Nor-Ray-Vac

NOR-RAY-VAC

Please contact sales on 01384 489700 for more information on Nor-Ray-Vac continuous radiant tube system

£POA

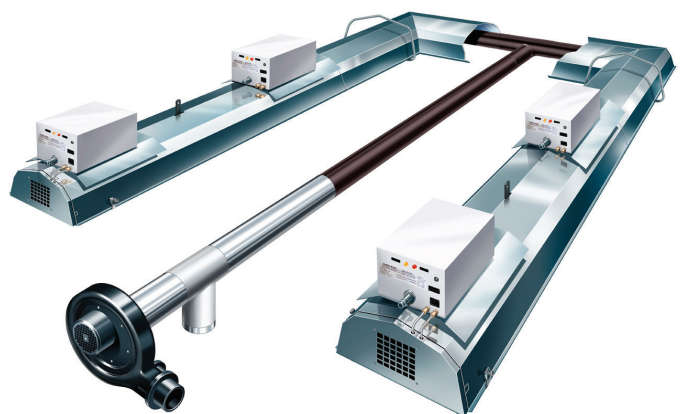



RHeco

Gas fired ultra high efficiency, low NO_x condensing, suspended warm air unit heater. Supplied with axial fan, modulating burner, automatic ignition, horizontal & vertical louvres.

PROPANE MODELS AVAILABLE

MODEL	HEAT INPUT KW	AIRFLOW (m3/h)	FLUE DIA (mm)	LIST PRICE
ULSA 025-2	25.0	2900	80	4822.46
ULSA 035-2	33.0	3700	80	5104.68
ULSA 050-2	50.0	5600	80	5296.26
ULSA 075-2	70.0	7900	100	6764.01
ULSA 100-2	94.0	10500	100	7477.80

EC modulating versions are also available that are manufactured with a supply modulating air fan as standard. Contact us to find out more about our high efficiency range.

RHeco Optional Equipment

PART NUMBER	DESCRIPTION	025	035	050	075	100
		LIST PRICE	LIST PRICE	LIST PRICE	LIST PRICE	LIST PRICE
-	Air outlet discharge 30° downturn nozzle	100.94	100.94	127.21	127.55	176.13
B-SC3ML-MZR	SmartCom multi zone control panel	483.11	483.11	483.11	483.11	483.11
29-01-219	Remote room sensor (for use with SmartCom)	75.92	75.92	75.92	75.92	75.92
	Sundries					
6506	½" BSP gas valve	21.32	21.32	-	-	-
6510	¾" BSP gas valve	-	-	23.54	23.54	23.54
6500	½" BSP flexible connection	57.75	57.75	57.75	57.75	57.75
6500-1	¾" BSP flexible connection	-	-	65.21	65.21	65.21
R-WMB2	Wall brackets	261.36	261.36	261.36	261.36	261.36
6529	Drop rods M10 x 3 metre	20.85	20.85	20.85	20.85	20.85



PHOTON

Gas fired unit heater with a high airflow axial fan for free blowing applications, a modulating burner and units are available for natural gas (G20, G25, G25.3) as standard.

P

MODEL	HEAT OUTPUT KW	AIRFLOW (m3/h)	FLUE DIA (mm)	LIST PRICE
PHOTON 10-2	9.34	1223	80	2487.45
PHOTON 20-2	18.39	2533	80	2736.71
PHOTON 25-2	26.54	3035	100	2861.34
PHOTON 35-2	31.68	4120	100	2984.94
PHOTON 45-2	42.24	4562	100	3109.57
PHOTON 55-2	53.46	5877	100	3482.43
PHOTON 65-2	63.59	7125	130	4104.86
PHOTON 70-2	71.25	8681	130	4167.38
PHOTON 100-2	97.87	10350	130	4789.50
PHOTON 120-2	120.16	17552	130	6467.37

DESCRIPTION	LIST PRICE 10	LIST PRICE 20	LIST PRICE 25/35/45	LIST PRICE 55/65	LIST PRICE 75	LIST PRICE 100	LIST PRICE 120
Air outlet discharge 30o downturn nozzle	256.34	291.43	289.65	521.75	588.08	580.45	727.38

PART NUMBER	DESCRIPTION	LIST PRICE 10/20/25	LIST PRICE 35/45/55/65/70/100	LIST PRICE 120
B-SC3ML-MZR	SmartCom multi zone control panel	483.11	483.11	483.11
29-01-219	Remote room sensor (for use with SmartCom) Sundries	75.92	75.92	75.92
6506	½" BSP gas valve	21.32	-	-
6510	¾" BSP gas valve	-	23.54	-
1023509	1" BSP gas valve	-	-	28.51
6500	½" BSP flexible connection	57.75	-	-
6500-1	¾" BSP flexible connection	-	65.21	-
1023510	1" BSP flexible connection	-	-	100.44
R-WMB1	Fixed Wall mounting Bracket Photon 10, 20	199.48	-	-
R-WMB2	Fixed Wall mounting Bracket Photon 25-100	261.36	261.36	-
6529	Drop rods M10 x 3 metre	20.85	20.85	20.85

Option 1 - Fan Assisted Stainless Steel Flue Only

DESCRIPTION		80 mm	100 mm	130 mm
Horizontal flue terminal	Part No.	33-54-006-FLUE21	33-54-106-FLUE25	33-54-206-FLUE26
	List Price	160.97	173.78	201.92
Vertical flue terminal	Part No.	33-54-007-FLUE22	33-54-107-FLUE4	33-54-207-FLUE10
	List Price	49.98	74.34	76.76
To connect with terminal & heater				
Pipe 1m length	Part No.	33-54-001-FLUE16	33-54-101-FLUE1	33-54-201-FLUE5
	List Price	36.65	40.95	57.75
Pipe 0.5m length	Part No.	33-54-002-FLUE17	33-54-102-FLUE23	33-54-202-FLUE6
	List Price	27.30	32.97	39.59
Pipe 0.25m length	Part No.	33-54-003-FLUE18	33-54-103-FLUE24	33-54-203-FLUE7
	List Price	21.42	24.36	36.65
90° Elbow	Part No.	33-54-005-FLUE20	33-54-105-FLUE3	33-54-205-FLUE9
	List Price	33.44	39.27	47.15
45° Elbow	Part No.	33-54-004-FLUE19	33-54-104-FLUE2	33-54-204-FLUE8
	List Price	30.45	25.94	40.95
Horizontal flue terminal guard (basket)	Part No.	39-15-001	39-15-001	39-15-001
	List Price	46.98	46.98	46.98
Flexible flashing for flat roof or corrugated sheets (single pipe)	Part No.	33-51-022	33-51-522	33-51-622
	List Price	109.20	86.10	226.70

Option 2 - Room Sealed Stainless Steel Flue Components

DESCRIPTION		80 mm	100 mm	130 mm
Horizontal concentric flue terminal assembly	Part No.	33-55-009-FLUE27	33-55-106-FLUE13	33-55-206-FLUE12
	List Price	201.18	251.06	362.88
Vertical concentric flue terminal assembly	Part No.	33-55-010-FLUE28	33-55-107-FLUE11	33-55-207-FLUE29
	List Price	288.12	377.79	466.31
To connect with terminal & heater				
Pipe 1m length	Part No.	33-54-001-FLUE16	33-54-101-FLUE1	33-54-201-FLUE5
	List Price	36.65	40.95	57.75
Pipe 0.5m length	Part No.	33-54-002-FLUE17	33-54-102-FLUE23	33-54-202-FLUE6
	List Price	27.30	32.97	39.59
Pipe 0.25m length	Part No.	33-54-003-FLUE18	33-54-103-FLUE24	33-54-203-FLUE7
	List Price	21.42	24.36	36.65
90° Elbow	Part No.	33-54-005-FLUE20	33-54-105-FLUE3	33-54-205-FLUE9
	List Price	33.44	39.27	47.15
45° Elbow	Part No.	33-54-004-FLUE19	33-54-104-FLUE2	33-54-204-FLUE8
	List Price	30.45	25.94	40.95
Horizontal flue terminal guard (basket)	Part No.	39-15-001	39-15-001	39-15-001
	List Price	46.98	46.98	46.98
Flexible flashing for flat roof or corrugated sheets (single pipe)	Part No.	33-51-022	33-51-522	33-51-622
	List Price	109.20	86.10	226.70



e+

The e+ provides a unique, gas-free alternative for warm air heating. With an instant start up time and adaptive control for additional energy savings.

MODEL	HEAT OUTPUT KW	AIRFLOW (m3/h) Speed F1	AIRFLOW (m3/h) Speed F2	LIST PRICE
EUH10	10	1275	1500	950.00
EUH20	20	2000	2250	1300.00
EUH30	30	3000	3250	1450.00

PART NO	DESCRIPTION	LIST PRICE
EUH-CTRL-KIT-10M	e+ Controller kit with 10m RJ45 cable	100.00
EUH-CTRL-KIT-30M	e+ Controller kit with 30m RJ45 cable	120.00
EUH-CTRL-KIT-50M	e+ Controller kit with 50m RJ45 cable	140.00



DS Destratification Fans

PART NUMBER	MODEL	PRIMARY AIRFLOW (m3/h)	MOUNTING HEIGHT	LIST PRICE
DS3-4	DS 3	3000	4 to 8m	585.04
DS4-4	DS 4	5300	6 to 12m	827.09
DS6-4	DS 6	6600	10 to 18m	844.60
DS10-4	DS 10	9000	10 to 18m	1043.39

DS Optional Equipment

PART NUMBER	DESCRIPTION	LIST PRICE
28-00-301	Stainless Steel wire roof fixing kit	116.32



POWERFOIL D

The Strong, Silent Type



Direct-drive motor for whisper quiet operation

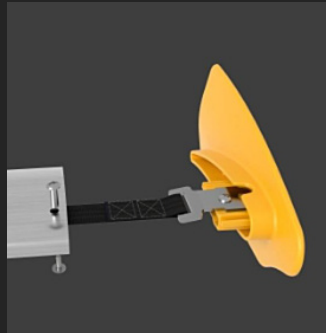

Patented airfoil design for best-in-class air movement

Nine redundant safety features for ultimate workplace security



New standard **IP66 rating** for use in harsh environments



7-year warranty



REZNOR® + BIG ASS FANS®

Raising the bar on high-tech fans, Powerfoil D is our premium direct-drive fan. We built this HVLS fan from the ground up for industrial and harsh environments, and its IP66 rating means it's able to withstand harsh elements like dust and water. Purposefully engineered to transform the way people feel and work within your space, Powerfoil D takes on hot, gritty conditions with ease and has the specs to excel in any facility where comfort and quiet are valued.

- Diameter options from 8-24 feet
- Six patented airfoils with winglets
- IP66 rating for indoor or outdoor use
- 15-year mechanical warranty; 5-year electrical (extended warranty available)
- Powerful Neodymium magnet motor provides virtually silent fan operation and optimum efficiency
- 200-277 / 338-480 multi-phase VAC options

High Volume Low Speed (HVLS) fans are large diameter fans designed to circulate high volumes of air while operating at low speeds. They create more comfortable conditions for people through enhanced floor to ceiling air circulation and temperature regulation with lower energy utilisation.

PART NUMBER	MODEL	DESCRIPTION	LIST PRICE
PFD12	Powerfoil D 12	3.6m HVLS fan	8233.82
PFD18	Powerfoil D 18	5.5m HVLS fan	8459.39
PFD24	Powerfoil D 24	7.3m HVLS fan	8797.23

PART NUMBER	MODEL	LIST PRICE
BAFCON	BAFcon Controller	790.01

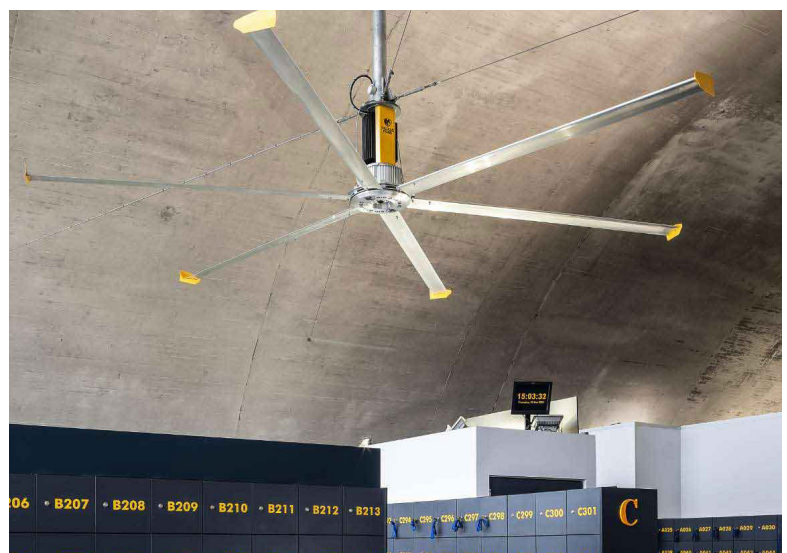



COMET+

The COMET+ range of cabinet heaters combines inovative design with proven heat exchanger technology to provide a efficient cost effective durable range. Standard efficiency models available with modulating burner with a 2:1 turn down with use with Natural Gas (G20) and Propane (G31). These models are also available with the use of both 35 sec and Kerosine oil. High efficiency (condensing) models are only available in Natural Gas (G20), with modulating burner with 4:1 turn down. All models have EC plug fans as standard.

ALL MODELS ARE AVAILABLE IN NATURAL GAS FIRED, PROPANE FIRED OR OIL FIRED VERSIONS. OIL FIRED MODELS ARE SUPPLIED WITH A FIRE VALVE AND AN OIL FILTER AS LOOSE COMPONENTS

COMET+ Standard efficiency unit (internal)

MODEL	HEAT OUTPUT KW	AIRFLOW (m3/h)	Available ESP (pa)	FLUE DIA (mm)	Natural Gas Fired		Oil Fired		Propane (LPG) Fired	
					Ducted (D-N)	Nozzled (N-N)	Ducted (D-O)	Nozzled (N-O)	Ducted (D-P)	Nozzled (N-P)
COMET045-2	45.00	3,276	250	130	8085.50	8600.50	8085.50	8600.50	8085.50	8600.50
COMET060-2	60.00	4,392	250	130	8497.50	9012.50	8497.50	9012.50	8497.50	9012.50
COMET090-2	90.00	6,552	250	130	8827.10	9342.10	8827.10	9342.10	8827.10	9342.10
COMET150-2	150.00	10,944	250	130	10918.00	11433.00	10918.00	11433.00	10918.00	11433.00
COMET180-2	180.00	13,104	250	200	11896.50	12669.00	11896.50	12669.00	11896.50	12669.00
COMET210-2	210.00	15,264	250	250	15398.50	16325.50	15398.50	16325.50	15398.50	16325.50
COMET300-2	300.00	21,816	250	250	18746.00	19673.00	18746.00	19673.00	18746.00	19673.00

COMET

Please contact sales on 01384 489700 for more information our COMET Cabinet heaters, and the team can provide selection advice.

COMET+ Standard efficiency unit (external)

MODEL	HEAT OUTPUT KW	AIRFLOW (m ³ /h)	Available ESP (pa)	FLUE DIA (mm)	Natural Gas Fired		Oil Fired		Propane (LPG) Fired	
					Ducted (D-N)	Nozzled (N-N)	Ducted (D-O)	Nozzled (N-O)	Ducted (D-P)	Nozzled (N-P)
COMET045-2-EX	45.00	3,276	250	130	10660.50	11175.50	10660.50	11175.50	10660.50	11175.50
COMET060-2-EX	60.00	4,392	250	130	11072.50	11587.50	11072.50	11587.50	11072.50	11587.50
COMET090-2-EX	90.00	6,552	250	130	11402.10	11917.10	11402.10	11917.10	11402.10	11917.10
COMET150-2-EX	150.00	10,944	250	200	13493.00	14008.00	13493.00	14008.00	13493.00	14008.00
COMET180-2-EX	180.00	13,104	250	250	16016.50	16789.00	16016.50	16789.00	16016.50	16789.00
COMET210-2-EX	210.00	15,264	250	250	19518.50	20445.50	19518.50	20445.50	19518.50	20445.50
COMET300-2-EX	300.00	21,816	250	250	22866.00	23793.00	22866.00	23793.00	22866.00	23793.00

COMET+ High efficiency/Condensing unit (internal)

MODEL	HEAT OUTPUT KW	AIRFLOW (m ³ /h)	Available ESP (pa)	FLUE DIA (mm)	Natural Gas Fired	
					Ducted (D-N)	Nozzled (N-N)
COMET045-2C	45.00	3,276	250	130	9630.50	10660.50
COMET060-2C	60.00	4,392	250	130	10042.50	11072.50
COMET090-2C	90.00	6,552	250	130	10372.10	11402.10
COMET150-2C	150.00	10,944	250	200	12463.00	13493.00
COMET180-2C	180.00	13,104	250	250	14162.50	15450.00
COMET210-2C	210.00	15,264	250	250	17664.50	19106.50
COMET300-2C	300.00	21,816	250	250	21012.00	22454.00

COMET+ High efficiency/Condensing unit (external)

MODEL	HEAT OUTPUT KW	AIRFLOW (m ³ /h)	Available ESP (pa)	FLUE DIA (mm)	Natural Gas Fired	
					Ducted (D-N)	Nozzled (N-N)
COMET045-2C-EX	45.00	3,276	250	130	12205.50	13235.50
COMET060-2C-EX	60.00	4,392	250	130	12617.50	13647.50
COMET090-2C-EX	90.00	6,552	250	130	12947.10	13977.10
COMET150-2C-EX	150.00	10,944	250	200	15038.00	16068.00
COMET180-2C-EX	180.00	13,104	250	250	18282.50	19570.00
COMET210-2C-EX	210.00	15,264	250	250	21784.50	23226.50
COMET300-2C-EX	300.00	21,816	250	250	25132.00	26574.00

DESCRIPTION		130mm	200mm	250mm
Starter Kit (Raincap, 1x 1m length, 1x storm collar, 1x Adjustable flashing kit, 1x Clamp band)	PART NO.	CF130-FK-2	CF200-FK-2	CF250-FK-2
	LIST PRICE	472.50	514.50	577.50
Universal Raincap	PART NO.	CF130-TERM-2	CF200-TERM-2	CF250-TERM
	LIST PRICE	94.50	118.80	156.60
1m length flue pipe	PART NO.	CF130-1M-2	CF200-1M-2	CF250-1M
	LIST PRICE	103.95	157.50	204.75
0.5m length flue pipe	PART NO.	CF130-0.5M-2	CF200-0.5M-2	CF250-0.5M
	LIST PRICE	68.25	102.60	135.00
90° elbow	PART NO.	CFT130-90ELB-2	CFT200-90ELB-2	CFT250-90ELB
	LIST PRICE	103.95	162.00	204.75
45° elbow	PART NO.	CFT130-45ELB-2	CFT200-45ELB-2	CFT250-45ELB
	LIST PRICE	103.95	162.00	210.60
90° Tee	PART NO.	CFT130-90TEE-2	CFT200-90TEE-2	CFT250-90TEE-2
	LIST PRICE	157.50	226.80	270.00
Joint clamp band	PART NO.	CF130-JC-2	CF200-JC-2	CF250-JC-2
	LIST PRICE	21.00	25.20	25.20
Storm Collar	PART NO.	CF130-SC-2	CF250-SC-2	CF250-SC-2
	LIST PRICE	129.60	129.60	151.20
EPDM Square black Flashing	PART NO.	CF130-FF1-2	CF200-FF1-2	CF250-FF1-2
	LIST PRICE	102.60	162.00	162.00
Flashing fixing kit	PART NO.	CF130-FF-FIX-2	CF200-FF-FIX-2	CF250-FF-FIX-2
	LIST PRICE	102.60	102.60	102.60

NOVAEMS

In addition to controlling, managing and monitoring heating, the innovative system contains a user-friendly panel with the added benefit of remote access.

KEY FEATURES:

HEATING CONTROL

Control and schedule heating with a selflearning system that averages a 43% reduction in energy consumption through greater efficiency.

MULTI-SITE CONTROLS

Schedule the on/off operation to reduce the maintenance and save energy.

REMOTE ACCESS & REPORTING

With a single point of control, view consumption, schedules and more from anywhere with internet access.

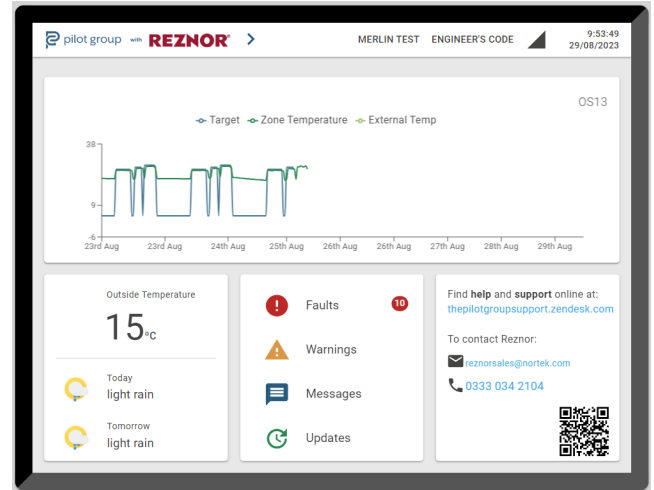

NOVA EMS SYSTEM FEATURES

HEATING CONTROL	REAL TIME MANAGEMENT CONTROL
Scheduling operation of heaters	Easy to navigate user interface ✓
Residual Heat Utilisation	Cloud based, enabling remote access ✓
Pre-Heat Optimisation utilising our self learning algorithm	Pre-Heat and End time optimisation ✓
Weather compensation	Live data graphs ✓
Accurate temperature control	Password protected access ✓
Process control monitoring to maximise efficiency and safety	Data export ✓
Door switch and failsafe strategy	Site map ✓



NOVAEMS

Please contact sales on 01384 489700 for more information our NOVAEMS, and the team can provide selection advice.

PRODUCT CODES

N-EMS-MP-2	NOVA EMS PANEL
N-EMS-SIM-UK	NOVA EMS - SIM CARD, PLUS LINE RENTAL AND DATA CHARGES FOR ONE YEAR - UK BASED
N-EMS-SIM-EU	NOVA EMS- SIM CARD, PLUS LINE RENTAL AND DATA CHARGES FOR ONE YEAR - EU BASED
N-EMS-SIM-US	NOVA EMS - SIM CARD, PLUS LINE RENTAL AND DATA CHARGES FOR ONE YEAR - US BASED
N-EMS-SE-EXT	NOVA EMS - EXTERNAL TEMPERATURE SENSOR
N-EMS-OS	NOVA EMS - OUTSTATION
N-EMS-SE-INT	NOVA EMS - INTERNAL TEMPERATURE SENSOR
N-EMS-SE-BBS	NOVA EMS - BLACK BULB SENSOR
N-EMS-SW-DS	NOVA EMS - ROLLER SHUTTER DOOR SWITCH
N-EMS-HB	NOVA EMS - HERRINGBONE UNIT
N-EMS-SW-FS	NOVA EMS - SUMMER FAN SWITCH
N-EMS-SW-OS	NOVA EMS - SIMPLE OVERRIDE SWITCH



NOVAEMS

Please contact sales on 01384 489700 for more information our **NOVAEMS**, and the team can provide selection advice.



HEATER CONDENS heating and ventilation devices are designed to be applied in buildings of small and medium capacity, especially as production and warehouse halls, car showrooms and service stations, sports halls and stadiums, sacral buildings and churches, retail stores and wholesale outlets, agricultural facilities, exhibition surfaces. HEATER CONDENS is a special, dedicated solution to be connected to low water temperature sources (for condensing boilers, industrial heat pumps). The main advantages of HEATER CONDENS are the high temperature of exhaust air generated by the low temperature of water supplied to a unit, maximum use of water coil surface – new geometry of coil construction (enhanced fins size, lower space between fins), optimised airflow exhaust – in effect high air exhaust temperature generated on each speed of the fan.

MODEL	DESCRIPTION	HEAT OUTPUT RANGE (kW)	Heat Output (70/50 C) ΔT air temp increase**	No. of unit rows	Airflow - III speed (m3/h)	Connection diameter	Power supply parameters (W/A)
SON-WA0015EC	Condens CR One	5 to 25	13kW / 25°C	2	1600	½" BSP	124W / 0.58A
SON-WA0017EC	Condens CR2	15 to 50	26kW / 22°C	2	3350	¾" BSP	250W / 1.08A
SON-WA0024	Condens CR2 MAX	25 to 70	40kW / 22°C	2	5700	¾" BSP	250W / 2.2A

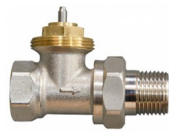

SONNIGER

Please contact sales on 01384 489700 for more information our Sonniger units, and the team can provide selection advice.

£POA

Sonniger Heater Condens

PART NUMBER	DESCRIPTION
SON-WAA0077	Sonniger HEATER ONE installation bracket
SON-WAA0028	Sonniger HEATER CR 2 installation bracket
SON-WAA0101	Sonniger HEATER CR 2 MAX installation bracket
SON-WAA0031	Sonniger Actuator TS Lite M30x1,5
SON-WAA0032	Sonniger Valve ASP/SSP Kvs 5,5
SON-CGA0003	Sonniger 1/2" straight Valve
SON-WAA0067	Sonniger External sensor ES01
SON-WAA0054N	Sonniger TR 110L Panel COMFORT speed regulation and thermostat
SON-WAA0035W	Sonniger INTELLIGENT Panel RL309 Wi-Fi
SON-WAA003EC	Sonniger INTELLIGENT Panel RL309 Wi-Fi EC
SON-WAA0055	Sonniger MULTI 6 AC splitter
SON-WAA0126	Sonniger MULTI 10 EC splitter

The Reznor ECHO Air rotation units are ideal for applications such as distribution centres and warehouses requiring frost protection or constant background temperatures. The system provides even heating over large areas and eliminates the requirement for ductwork or de-stratification fans.

Simple fast track installation provides an economic and efficient solution with low ongoing maintenance costs.

The range are both UKCA and CE approved units with thermal efficiency in excess of 91% ECHO Air Rotation provides a simple cost effective solution by utilising a much greater supply air volume with only a low temperature rise.

The system draws in the cooler air at low level and rotates the air to high level where it mixes with the warmer air. This develops a gentle airflow pattern, displacing the high level hot air and returning it to floor level to provide automatic de-stratification.

When additional heat is required the supply air is tempered to give a minimal temperature difference between air discharge and the space temperature so that the natural tendency of the hot air to stratify is virtually eliminated. The rotation of large air volumes of tempered air provides even wall to wall and floor to roof temperature distribution and allows heat gains from lighting and other sources to be re-circulated to low level to reduce energy consumption.

Model Range

The ECHO range has four models; Lieutenant, Captain, Major and Colonel. Each model has a maximum and minimum kW Output, plus a maximum and minimum Airflow range.

Available as heated (via Natural Gas or Propane) or as a De-stratification model (no heat).

ECHO

ECHO

Please contact sales on 01384 489700 for more information our ECHO Air rotation units, and the team can provide selection advice.

£POA



Features and Benefits

- Large areas heated by a single unit so that number of units is reduced to a minimum
- Fewer units, all sited at low level reduces ongoing maintenance costs
- No requirement for high level destratification fans
- No requirement for costly ductwork installation
- Higher thermal efficiency for reduced running costs
- Heat outputs up to 586kW from a single unit
- High burner turndown ratio for closer temperature control



The Reznor GENCO Modular air system is a range of heating, cooling, and ventilation units, offering energy efficient solutions for large open areas.

The modular system can be configured to provide various Heating and Cooling outputs with differing battery types for a range of air volumes for both supply and extract. This allows our teams utilize the modules to suit your needs.

Model Range Outputs

- Air volume range; 5m³/s to 25m³/s
- External static pressure available up to 1000pa
- Heat Outputs 128kW to 606kW
- Cooling Outputs

Modules includes:

Fan Only Module

- Supply Air Module
- Extract Air Module

Heater Module

- Indirect gas fired heat exchanger
- Direct gas fired heat exchanger
- Electric heating coil (max 117kW)
- LPHW heating coils
- DX heat pump coils

Cooling Module

- DX cooling coil
- Chilled water coil

Filter Module

- Slimline filter section (Panel filters)
- Standard filter section (Bag Filtration)

Silencer Module

Mixing Box Module

Cross flow heat recovery Module

GENCO

GENCO

Please contact sales on 01384 489700 for more information our GENCO Modular air system, and the team can provide selection advice.

£POA



The Air Mix high induction air distribution system is an innovative concept that is quick and easy to install, reliable, and inexpensive in operation. It provides an evenly diffused distribution of warm air and is ideal for open warehouse or retail areas without false ceilings.

The system utilises a lightweight duct that has a large number of small outlet nozzles, either evenly spaced along the length of the duct or located in specific areas.

Air is introduced into the duct and forced out of the nozzles at high speed, creating a negative pressure zone - thereby inducing surrounding air and recirculating "free heat" from lighting and heat that has risen to the roof space which would normally be wasted.

The result is a very evenly distributed heat at low air velocities and low noise levels, eliminating excess heat stratification and the need for air re-circulation fans.

Model Range

The Air Mix diffusers are made with airtight fireproof fabric, which thanks to a special treatment will remain unaltered over time. They are available in a range of diameters & colours, all are supplied complete with assembly kit.

The kit includes:

- Tailor made duct
- Fixing bands
- Suspension system

Specification

Air Mix is centred on an innovative duct system manufactured from a fire resistant coated fabric, specially treated against dust, and acid vapours for guaranteed stability.

The system allows the use of smaller duct diameters, reducing the weight on the building structure and reduces installation time.

AIRMIX

AIRMIX

Please contact technical design on 01384 489700 for more information on AirMix induction air distribution systems

£POA



Each system is custom designed and manufactured in accordance with individual specifications, with the number, layout and diameter of ducts determined for maximum efficiency. Ducts are available in a wide range of colours to suit the decor of the location and require no further decorative finish on site. Final adjustments are carried out after installation and the system needs minimal maintenance.



Reznor Smitsair® offer an alternative air induction system that gives optimal air distribution in large open space premises, such as market halls and warehouses.

The aerodynamic construction of the nozzles makes it possible to achieve airflow velocities of 10 to 30m/s at a proportionally low nozzle pressure. The nozzles may be applied in groups on plenums or spaced out along a conventional duct system, allowing for flexible or irregular heating patterns in any large premises.

Primary air at high velocity entrains and recirculates large volumes of secondary air to produce a comfortable working environment.

The nozzles are easy to fit or remove by hand and the direction of the airflow can be adjusted after assembly from 0° to 60°. Air throw - from 15 to 50 metres - is calculated before assembly and may be adjusted during installation.

The Smitsair® system can be used to heat, cool or ventilate large spaces with negligible differences in vertical and horizontal air temperatures.

Features & Benefits

- Low static pressure
- Uniform distribution of air
- Adjustable nozzles
- Long throws available
- Low noise
- Available in black or white

SMITSAIR

SMITSAIR

Please contact technical design on 01384 489 250 for more information on Smitsair high induction systems

£POA



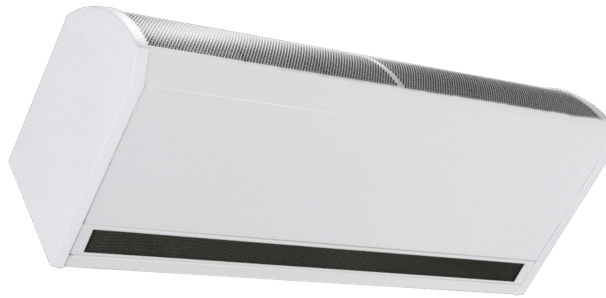

**GUARDIAN
GS**

Guardian GS series are commercial/retail air curtains designed for suspension via drop rods, or wall mounting via optional wall brackets, to serve doors/entrances. Standard colour is white (RAL9003), other RAL colours are available at additional cost. Comes with Signal Pro controller as standard

AVAILABLE IN THREE VERSIONS:- AMBIENT (UNHEATED), ELECTRIC (HEATED) OR LPHW (HEATED)

Electric (heated) Models

MODEL	HEAT OUTPUT kW	DOOR WIDTH (mm)	MAX DOOR HEIGHT (mm)	MAX AIRFLOW (m3/h)	LIST PRICE
GS1000E	9/12	1000	4000	1800	1970.64
GS1500E	12/18	1500	4000	2700	2685.83
GS2000E	18/24	2000	4000	3600	3347.19

LPHW (heated) Models

MODEL	HEAT OUTPUT kW	DOOR WIDTH (mm)	MAX DOOR HEIGHT (mm)	MAX AIRFLOW (m3/h)	LIST PRICE
GS1000W	12.0	1000	4000	1800	2380.50
GS1500W	18.0	1500	4000	2700	2778.98
GS2000W	24.0	2000	4000	3600	3439.31

Ambient (no heating) Models

MODEL	DOOR WIDTH (mm)	MAX DOOR HEIGHT (mm)	MAX AIRFLOW (m3/h)	LIST PRICE
GS1000A	1000	4000	1800	1886.81
GS1500A	1500	4000	2700	2680.65
GS2000A	2000	4000	3600	3261.29

Guardian Optional Equipment

PART NUMBER	DESCRIPTION	LIST PRICE
GS-FXT	Emergency exit kit (customer fit)	169.05
GS-WMB	Wall mounting (suspension) brackets (pair)	63.67
	Finish to specific RAL Colour	POA

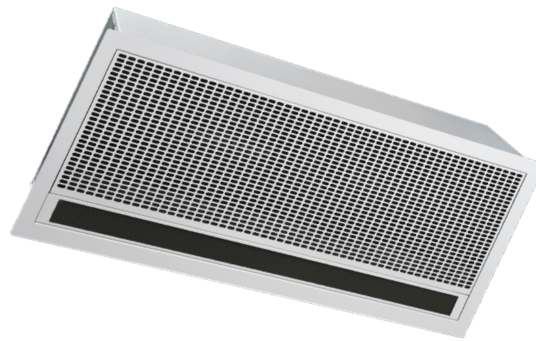

GUARDIAN GR

Guardian GR series are (recessed cased) commercial/retail air curtains designed for discreet positioning in a suspended ceiling or bulkhead above doorways. Standard colour for the grille surround is white (RAL9003). Comes with Signal Pro controller as standard

AVAILABLE IN THREE VERSIONS:- AMBIENT (UNHEATED), ELECTRIC (HEATED) OR LPHW (HEATED)

Electric (heated) Models

MODEL	HEAT OUTPUT kW	DOOR WIDTH (mm)	MAX DOOR HEIGHT (mm)	MAX AIRFLOW (m3/h)	LIST PRICE
GR1000E	9/12	1000	4000	1800	2487.11
GR1500E	12/18	1500	4000	2700	3592.49
GR2000E	18/24	2000	4000	3600	4241.43

LPHW (heated) Models

MODEL	HEAT OUTPUT kW	DOOR WIDTH (mm)	MAX DOOR HEIGHT (mm)	MAX AIRFLOW (m3/h)	LIST PRICE
GR1000W	12.0	1000	4000	1800	3415.50
GR1500W	18.0	1500	4000	2700	3881.25
GR2000W	24.0	2000	4000	3600	4140.00

Ambient (no heating) Models

MODEL	DOOR WIDTH (mm)	MAX DOOR HEIGHT (mm)	MAX AIRFLOW (m3/h)	LIST PRICE
GR1000A	1000	4000	1800	2278.04
GR1500A	1500	4000	2700	3330.63
GR2000A	2000	4000	3600	3237.48

Options

PART NUMBER	DESCRIPTION	LIST PRICE
RJ45-CABLE-2	Plug and play cable 2m	24.57
RJ45-CABLE-10	Plug and play cable 10m	33.60
RJ45-CABLE-20	Plug and play cable 20m	50.93
RJ45-CABLE-30	Plug and play cable 30m	65.94
RJ45-CABLE-50	Plug and play cable 50m	93.98
RJ45-CABLE-100	Plug and play cable 100m	255.99
RJ12-CABLE-3	Plug and play cable 3m (ACV-ACVRD only)	26.46
RJ12-CABLE-5	Plug and play cable 5m (ACV-ACVRD only)	29.82
RJ12-CABLE-10	Plug and play cable 10m (ACV-ACVRD only)	32.66
RJ12-CABLE-15	Plug and play cable 15m (ACV-ACVRD only)	44.94
RJ12-CABLE-40	Plug and play cable 40m (ACV-ACVRD only)	83.48
RJ12-CABLE-CONNECT	Connector for 2 x RJ12 cables	22.26
RJ45-CABLE-CONNECT	Connector for 2 x RJ45 cables	22.89
SC-OS	Outside sensor	85.05
AC-DC	Door contact set	70.96
AC-TC	Honeywell timeclock	168.11
108221-RJ45-2	Signal Pro Controller (comes with unit as standard)	186.95



Time Clock



Door Magnet Set



Outside Sensor



RJ12 Cable



108221-RJ45-2



Recessed Model



Wireless Controller



Surface Mounted Model

AC & ACR MINI

AC & ACR Mini series are commercial/retail air curtains designed for use over doors, mounted on walls or ceiling (AC). The ACR model allows positioning in a suspended ceiling or bulhead above doorways where low visual impact is required. All models include electric heating as standard.

Surface Mounted (Electric 1ph) - Wireless Controller Ready

MODEL	HEAT INPUT	DOOR WIDTH (mm)	MAX DOOR HEIGHT (mm)	MAX AIRFLOW (m3/h)	LIST PRICE
MINI600SE3-RX	33.0	600	1800	273	687.24
MINI800SE4-5-RX	4.5	800	2700	382	875.61
MINI1000SE6-RX	6.0	1000	3600	382	965.66
1Z-RX		Wireless controller (up to 16 units)			181.13

Recessed (Electric 1ph) - Wireless Controller Ready

MODEL	HEAT INPUT	DOOR WIDTH (mm)	MAX DOOR HEIGHT (mm)	MAX AIRFLOW (m3/h)	LIST PRICE
ACRMINI3-RX	600	600	1800	180	897.35
ACRMINI4-5-RX	800	800	2700	216	987.39
ACRMINI6-RX	1000	900	3600	432	1238.90
1Z-RX		Wireless controller (up to 16 units)			181.13



ACT SERIES

ACT series is an electric heater that directs a downflow of warm air from overhead. Available as either a recessed or surface mounted models.

Recessed (Electric 1ph) - Wireless Controller Ready

MODEL	HEAT INPUT	DIMENSIONS (mm)	MOUNTING HEIGHTS (mm)	LIST PRICE
ACT03R-RX	3	220H x 600W x 600D	3000	693.45
ACT04R-RX	4.5	220H x 600W x 600D	3500	881.82
ACT06R-RX	6.0	220H x 600W x 600D	3500	988.43
1Z-RX	Wireless controller (up to 16 units)			181.13

Surface Mounted (Electric 1ph) - Wireless Controller Ready

MODEL	LIST PRICE
ACTKIT-1	Surface Mounted Kit 221.55

NOTE: This kit turns a recessed unit into surface mounted.

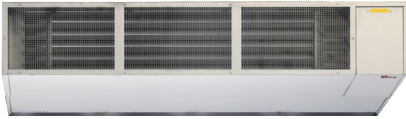

Single Module



Double Module

AB

AB industrial air curtains are for horizontal use above doors up to 6.0m high and available from 1.75m wide up to 6.75m. They are available in ambient (unheated), gas heated, electric heated and LPHW heated versions, with steam heated versions available on request. Control panels are available as an option.

Ambient (no heating)

MODEL	NO OF MODULES	MAX DOOR HEIGHT (m)	LENGTH (m)	QTY OF BRACKETS FOR VERTICAL MODELS	LIST PRICE
AB175A-2	1	6.0	1.75	2	3559.37
AB225A-2	1	6.0	2.25	2	4378.05

LPHW Heated

MODEL	NO OF MODULES	HEAT INPUT kW	MAX DOOR HEIGHT (m)	LENGTH (m)	TEMP RISE °C	LIST PRICE
AB175W-2	1	60.0	6.0	1.75	16	6008.18
AB225W-2	1	70.0	6.0	2.25	16	7019.37

NOTE: AB Air Curtains are made up of 1.75m & 2.25m size modules. Please see table below for unit make-up.

UNIT MAKE-UP
AB175 = 1 x AB175
AB225 = 1 x AB225
AB350 = 2 x AB175
AB400 = 1 x AB175 + 1 x AB225
AB450 = 2 x AB225
AB525 = 3 x AB175
AB575 = 2 x AB175 + 1 x AB225
AB625 = 1 x AB175 + 2 x AB225
AB675 = 3 x AB225

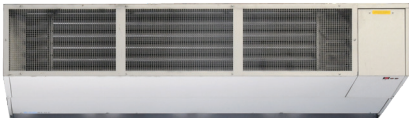

Single Module



Double Module

Gas Heated

MODEL	NO OF MODULES	HEAT INPUT kW	MAX DOOR HEIGHT (m)	LENGTH (m)	TEMP RISE °C	LIST PRICE
AB175N-2	1	40.0	6.0	1.75	12	6097.19
AB225N-2	1	54.0	6.0	2.25	12	7033.86

NOTE: AB Air Curtains are made up of 1.75m & 2.25m size modules. Please see table below for unit make-up.

Electric Heated

MODEL	NO OF MODULES	HEAT INPUT kW	MAX DOOR HEIGHT (m)	LENGTH (m)	TEMP RISE °C	LIST PRICE
AB175E-2	1	18.0	6.0	1.75	16	4845.87
AB225E-2	1	24.0	6.0	2.25	16	5138.78

NOTE: AB Air Curtains are made up of 1.75m & 2.25m size modules. Please see table below for unit make-up.

UNIT MAKE-UP

AB175 = 1 x AB175

AB225 = 1 x AB225

AB350 = 2 x AB175

AB400 = 1 x AB175 + 1 x AB225

AB450 = 2 x AB225

AB525 = 3 x AB175

AB575 = 2 x AB175 + 1 x AB225

AB625 = 1 x AB175 + 2 x AB225

AB675 = 3 x AB225

AB Accessories

PART NUMBER	DESCRIPTION	LIST PRICE
CP-AB-AMBI	Ambient models controller	1020.00
CP-ABGAS-SINGLE-2	Gas models controller (1 module)	3097.50
CP-ABGAS-TWIN-2	Gas models controller (2 module)	3272.83
CP-ABGAS-TRIPLE-2	Gas models controller (3 module)	3331.27
1030251	Electric models controller AB175	3591.00
1030252	Electric models controller AB225	POA
1030253	Electric models controller AB350	2940.00
1030254	Electric models controller AB400	5292.00
1030255	Electric models controller AB450	5292.00
1030256	Electric models controller AB525	POA
1030258	Electric models controller AB625	7256.03
1030259	Electric models controller AB675	POA
CP-AB-LPHW-SINGLE	LPHW models controller (1 module)	3447.50
CP-AB-LPHW-TWIN	LPHW models controller (2 module)	3642.64
CP-AB-LPHW-TRIPLE	LPHW models controller (3 module)	3707.69
N1611	Door Switch - All Controllers	184.14
N7041	Room Thermostat - All Controllers	69.98
6500-1	¾" Flexible gas connection for AB gas models	65.21
6510	¾" BSP Gas valve for AB Gas models	23.54



Radiant Heating Equipment

MODELS

Vision, Sonning?, SCR-ECO,
Electric Quartz

All models carriage charged at 8% of net invoice.
(minimum charge £200.00, maximum charge £1200.00 per delivery)

Warm Air Unit Equipment

MODELS	SIZE	QUANTITY		
		1	2-4	5
RHeco	25 - 50	£138.00 each	£128.00 each	£120.00 each
	75 - 100	£178.00 each	£164.00 each	£154.00 each
PHOTON	10 - 45	£101.00 each	£95.00 each	£90.00 each
	55 - 120	£143.00 each	£133.00 each	£123.00 each
e+	All models (Next Day Delivery)	£65.00 each	£62.00 each	£59.00 each

Destratification Fans

MODELS	DELIVERY OPTIONS	QUANTITY		
		1	2-4	5+
All Models	3-4 days	£40.00 each	£30.00 each	£25.00 each
	Next day	£71.00 each	£60.00 each	£55.00 each

Commercial Air Curtains

MODELS	DELIVERY OPTIONS	QUANTITY		
		1	2-4	5+
Guardian AC / ACR Mini, ACT	Next day	£69.00 each	£59.00 each	£54.00 each
	Next day	£43.00 each	£39.00 each	£37.00 each
All Models	Next day before 9:00 am	£97.00 each	£86.00 each	£82.00 each

Industrial Air Curtains

MODELS	NO OF MODULES	QUANTITY		
		1	2-4	5+
AB	1	£90.00 each	£74.00 each	£67.00 each
	2	£138.00 each	£117.00 each	£106.00 each
	3	£184.00 each	£154.00 each	£146.00 each

Flue

DESCRIPTION	
Flue only	All flue carriage charge 6% of net invoice (minimum charge £35.00)
Flue shipped with heater orders	Free of charge

Off-loading is the responsibility of the customer, if you require special off-loading facilities please call the UK sales office on 01384 489 700

Carriage Charge Information

- UK mainland only, other destinations P.O.A
- Hiab and other special requirements P.O.A
- All prices ex-works Brierley Hill
- All equipment sold subject to Conditions of Sale
- Transport charges are not subject to trade discount
- Carriage charges maybe subject to a fuel surcharge
- All prices based upon 3 working day delivery unless specified; next working day delivery add £35.00 per unit
- Next day deliveries based on ex-stock units being delivered next working day on orders received before 12.00 noon

We will confirm a site date upon receipt of full instructions and paperwork.
No order shall be binding until acknowledged by Nortek Global HVAC in writing.
The products covered by this price list are all deemed to be of standard colour, duty and specification.
All prices are ex-works. Carriage will be charged at the rate ruling at date of despatch.
Minimum order charge £25.00 plus p&p on small items.
VAT will be additionally charged at the ruling rate on date of invoice.

Payment Terms

30 days from date of invoice for approved accounts. Payment prior to despatch and early payment discounts quoted upon request.

Returns Policy

We hope you will be completely satisfied with any product or component purchased from Nortek Global HVAC UK Ltd, but if you wish to return an item, we aim to make it as quick and convenient as possible.

Returns Process

Please call 01384 489 700 and select from one of the options for the relevant product return.

Please have your return details ready and our trained staff will guide you through the process. On acceptance a returns material authorisation number will be given which must be included both on the packaging and returns paperwork. Upon the issuing of an RMA number, goods must be returned to us within 10 working days. We are unable to process any goods returned without an RMA number.

Not all requests to return goods will be accepted.

Damaged in Transit

If you take delivery of a product that has been damaged in transit, the goods must be checked and any damage reported in writing within 3 working days. Claims made outside this period will not be considered. The product then requires return/collection within 10 working days.

Return of Faulty Goods

Should a fault develop with a product purchased from us within the first year of ownership, please contact our Service department with details of the fault and we will advise you how to proceed. Nortek Global HVAC UK Ltd reserves the right to either replace or repair faulty item(s). Should we deliver a replacement item we will invoice for it, crediting the faulty item upon receipt.

Ordered Incorrectly/Incorrectly Supplied/Not Required

If an item has either been ordered incorrectly, incorrectly supplied or is not required, it can be returned within 30 days from purchase as long as it remains unused, in new condition and with all packaging and labels intact. Should Nortek Global HVAC UK Ltd incur any costs in re-working or re-packaging the returned items to a re-saleable condition, this will affect the amount of credit due.

Returned items that have been ordered incorrectly or are not required will incur a 25% restocking charge. If these items are collected, a collection charge will also apply. Heaters built to customer specification will not be eligible for return; any cancellation prior to despatch will be subject to a charge relevant to costs incurred.

Excess Items

Nortek Global HVAC UK Ltd systems are designed using the information available to us at the time. Due to the high cost of handling and risk of damage, it is not possible for excess Nor-Ray-Vac, herringbone materials or warm air flue to be returned for credit.

Delivery Dates

All dates quoted for delivery are approximate only and Nortek Global HVAC UK Ltd shall not be liable for the delay in delivery of goods however caused. You are advised to ensure that goods have been delivered to the required location before committing labour.

Radiant heater stillage

For large radiant heater orders, components are delivered on stillages, which should be unloaded upon receipt and returned to the delivery vehicle. Failure to do so will result in additional charges to collect and return stillage(s).

What is covered under our standard warranty:

All heaters, controls and accessories supplied as part of a new heating system

WARRANTY	
Labour	1st Year
Parts - Excludes consumables (i.e belts, filters, fuses, Quartzglow bulbs etc)	1st and 2nd Year
Access equipment and tool hire	1st Year
Carriage cost for replacements	1st Year

Exceptions for new installations

DESCRIPTION	
DS destratification fans	1st Year (parts only)

Spare parts

WARRANTY	
Controls and accessories supplied as spares (excl consumables)	1st Year
General spare parts (excl consumables)	1st and 2nd Year
Carriage cost for replacement spares	1st Year
Labour for replacement spares	1st Year

Standard warranty period

Date of start: From date of despatch or commissioning date (if no more than 90 days from date of despatch and conducted by a Nortek Global HVAC UK Service Engineer) Commissioning report and documentation will be required.

Who is covered?

Who holds the warranty?: The purchasing customer account holds the warranty.

Payment of items in warranty: Payment has to either have been settled or still be within the agreed account payment terms e.g. an account with a 30 day payment term.

Commissioning and service of units: Proof of commissioning and annual service reports must be supplied by the customer.

Not covered: Unauthorised modifications to equipment

Payments

Warranty parts only request: Customers requesting parts only will be invoiced for the items and carriage. Upon return and our receipt of the faulty items and our agreement as to the warranty, a credit for the value of the invoice will be made.

Under warranty engineer site visits: We will send a 'Warranty' form, this should be completed and returned with an order for site attendance. Customers will only be charged if the call out is not covered by warranty and after full negotiation between ourselves and the customer.

Cash customers: Cash customers should pay pro-forma for the day labour rate and any parts that may be required. If the call-out is found to be covered by warranty then a credit for all items covered by the warranty will be issued.

Standard call-out policy

Engineer call-outs: We aim to attend site upon receipt of full instructions and paperwork. We will however do all we can to meet any specific customer requirements.



REZNOR®

Nortek Global HVAC UK Limited
Fens Pool Avenue | Brierley Hill
West Midlands | DY5 1QA | UK
T: 01384 489 700 | F: 01384 489 707

Registered in England No. 01390934 | Registered Office:
Nortek Global HVAC UK Limited, Fens Pool Avenue,
Brierley Hill, West Midlands, DY5 1QA
Nortek Global HVAC is a registered trademark
of Nortek Global HVAC Limited.
Because of continuous product innovation,
Nortek Global HVAC reserves the right to
change product specification without due notice.

ALL PRICES ARE EX WORKS | E&OE